

Thank you for choosing ShoreLand'r!

Here are the operating instructions for your new trailer. Please read this document carefully before using your trailer and keep it in a safe place for future reference.

If you have any questions about your trailer or need service, contact your local ShoreLand'r® dealer. If you have difficulty contacting a dealer, please call our Customer Service Department at (800) 859-3028 or e-mail: shorelandr@midwestindustries.com, so we can assist you in contacting a dealer.

For Parts lookup and directions to a parts dealer: www.shorelandr.com/parts, click on - Partsmart Online Parts finder.

You should have received a packet of warranty documents with your trailer. Be sure to fill out and mail your Warranty Registration Card to activate your trailer's warranty. If you did not receive this information, ask your dealer for a copy or visit www.shorelandr.com and register online.

Please fill in the following information for your records

Model Year: _____

Model: _____

Vehicle Identification Number: _____

Carrying Capacity: _____

Date Purchased: _____

Purchased From: _____

Phone Number: _____

Tire Size: _____

Recommended Air Pressure: _____

All ShoreLand'r trailers are certified by the National Marine Manufacturer's Association.

Models and specifications are subject to change. Some models are shown with optional equipment. Because of the continual improvements to our trailers, ShoreLand'r reserves the right to add or discontinue models at any time or to change design and specifications without notice and incurring obligations.

Table of Contents

Specifications & General Information		Basic Tire Maintenance	
Matching Your ShoreLand'r to Your Boat.....	2	Recommended PSI & Maximum Load Capacity.....	11
Load Carrying Capacity	3	Understanding Tire Pressure & Load Limits	11
Weight Distribution / Tongue Weight.....	3	Maintaining Proper Tire Pressure	11
Tow Vehicles	4	Tire Size.....	12
Trailer Balls and Coupler	4-5	Tire Tread.....	12
Safety Chains.....	5	Tire Balance and Wheel Alignment.....	12
Proper Winch Post Adjustment	6	Tire Repair	12
Bow Eye Safety Chain	6	Changing Tire.....	12
Winch Handles.....	6	Excessive Tire Wear	12
Bow Pulpits and Winch Post Lengths	6	Using Your ShoreLand'r	
Tire Safety.....	6-7	Safety Instructions & Warnings.....	12-13
Brake Information.....	8	Warnings & Precautions	13
Tie Downs	8	Trailer Tips	14-15
Troubleshooting & Maintenance		Tire Information	
Lighting	8-9	Determining Correct Load Limits	16
Paint and Its Care	9	Tire Safety.....	16
Repacking Bearings.....	9	Tire Fundamentals	16
Hubs, Bearings, Races & Seals Chart.....	10	Information on Passenger Vehicle Tires	16
Use & Service Tips for Wheel Bearing Protectors	10	UTQGS (Uniform Tire Quality Grading System) Info.....	16
When to Check the Grease in Hubs	10	Glossary of Tire Terminology	17-19
Grease Seals	10	Reporting Safety Defects.....	19
Bearing Adjustment	10	Warranty Information	19
Recommended Lubricant.....	11	Parts Look-up & Sales.....	19
Brake System Overview	11		

YOU & YOUR SHORELAND'R

We at ShoreLand'r would like to thank you for purchasing one of our trailers!

Our goal is your complete satisfaction, that is why we recommend reading this manual in its entirety. A better understanding of your trailer's features, regulations and adjustments will make your boating experience more pleasurable.

It is important that you give your new trailer proper care and maintenance to ensure that it continues to provide the dependable performance year after year.

Happy trailering!

IMPORTANT: Read this manual carefully with special attention directed toward all WARNING, CAUTION and IMPORTANT information.

Should a problem arise, please contact the dealer from whom the original purchase was made. You may also call our distributor for your area or our Customer Service Department by phone at 800-859-3028 or e-mail shorelandr@midwestindustries.com. We will be glad to help you locate a dealer who can best meet your needs. Our dealer locator is also available at www.shorelandr.com.

NOTICE

This trailer is equipped to meet all applicable U.S. Federal safety standards. Check local and state requirements regarding brakes and any additional equipment that may be required. Any modifications or additions including load equalizing hitches, without written factory consent or usage in an abnormal manner, including overloading, voids all manufacturers warranties and liability.

MATCHING YOUR SHORELAND'R TO YOUR BOAT

The key to carefree boat trailering is proper matching of the trailer to your boat. A proper match is one in which the trailer is designed and built to carry a load which will match your total combined weight of boat, motor, gas tanks, water tanks, and miscellaneous gear which might be added. The trailer should also be wide enough to give the boat good stability, plus long enough so that you have proper support for the transom of the boat.

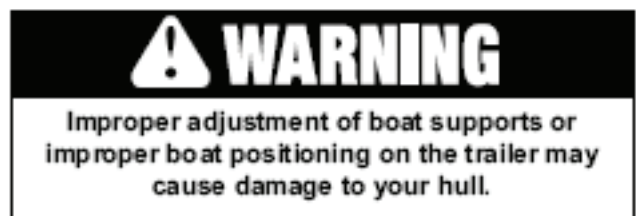

LOAD-CARRYING CAPACITY

Check the tag located on the inside left forward part of the trailer frame. It will show the Gross Vehicle Weight Rating (GVWR), which is the load-carrying capacity plus the weight of the trailer itself. Note that the frame tag may have anywhere from one to three different GVWR's listed on the tag. See example below. Check the size and load range of the tires on your trailer. The GVWR of your trailer would be that of the corresponding tire size on the tag.

NOTE: Maximum load carrying capacity is the gross vehicle weight rating (GVWR) less the weight of the empty trailer. The total weight of your boat, engine, fuel, water and gear must not exceed the trailer's maximum load carrying capacity. Overloading can cause serious injury or property damage.



TIRE & LOADING INFORMATION

The weight of cargo should never exceed 2087 kg. or 4600 lb.

	TIRE SIZE	COLD TIRE PRESSURE	SEE OWNER'S MANUAL FOR ADDITIONAL INFORMATION
FRONT	ST185/80R13C	343 KPA, 50 PSI	
REAR	ST185/80R13C	343 KPA, 50 PSI	
SPARE	ST185/80R13C	343 KPA, 50 PSI	

1MDZZ4W236Z000000

MFD. BY /
FABRIQUÉ PAR:



INDUSTRIES, INC.
IDA GROVE, IA 51445

COLD INFL PRESS. /
DE GONF À FROID

MAX. LOAD CARRYING CAPACITY

GVWR / PNBV
KG (LB)
2685 (5920)

GAWR / PNBE
EACH AXLE
KG (LB)
1343 (2960)

DATE: 06/2005
SIZE / DIMENSION
TIRE / PNEU
RIM / JANTE
ST 185/80R13C 13X4.5 J

KPA (PSI)
343 (50)

KG (LB)
2087 (4600)

THIS VEHICLE CONFORMS TO ALL APPLICABLE US FEDERAL MOTOR VEHICLE SAFETY STANDARDS IN EFFECT ON THE DATE OF MANUFACTURE SHOWN ABOVE.

V.I.N. / N.I.V. 1MDZZ4W236Z000000 TRAILER 2X5 46TB ALUMINUM 2006

THIS VEHICLE CONFORMS TO ALL APPLICABLE STANDARDS PRESCRIBED UNDER THE CANADIAN MOTOR VEHICLE SAFETY REGULATIONS IN EFFECT ON THE DATE OF MANUFACTURE.

CE VÉHICULE EST CONFORME À TOUTES LES NORMES QUI LUI SONT APPLICABLES EN VERTU DU RÈGLEMENT SUR LA SÉCURITÉ DES VÉHICULES AUTOMOBILES DU CANADA EN VIGUEUR À LA DATE DE SA FABRICATION.

PROPER WEIGHT DISTRIBUTION & TONGUE WEIGHT

Ensuring that your trailer has the proper GVWR is very important. Once that has been established and you have the boat on the trailer, it is equally important that you have proper weight distribution.

Tongue Weight

Ideally, you should have 5% to 7% of the total weight of your loaded trailer on the hitch coupler. This is called tongue weight and can be measured using an ordinary bathroom scale with the trailer's tongue parallel to the ground.

EXAMPLE: If the gross vehicle weight of the trailer, boat and gear is 2,000 pounds, the tongue weight should be between 100 and 140 pounds to fall into the recommended 5% to 7% range.

Not enough tongue weight can cause the trailer to "fishtail" (sway from side to side) as you travel down the highway. This creates excessive strains on the tow vehicle, hitch and also the trailer itself, which can cause a serious accident.

WARNING

Fishtailing caused from improper tongue weight on the tow vehicle hitch ball can cause loss of control of the tow vehicle and result in serious injury or property damage.

To adjust for too little tongue weight, the axle(s) must be moved backward on the trailer allowing more weight to be carried on the tongue. On most ShoreLand'r models, this can be accomplished by loosening the U-bolts that fasten the axle to the trailer frame. Adjust until the tongue weight falls within the recommended 5% to 7% range. One inch of movement equals approximately 10-15 lbs. of tongue weight.

NOTE: Some smaller trailers do not have an adjustable axle. On these units either the boat or the gear inside must be moved forward or backward to achieve proper tongue weight.

To adjust for too much tongue weight, move the axle/axles forward until the tongue weight falls in the recommended 5% to 7% range.

If only a slight weight adjustment is required, it is possible to move the gear inside the boat to compensate the difference. Some tow vehicles require less tongue weight than others.

The 5% to 7% guideline is sufficient for most standard size boats. With smaller boats from 1000 pounds and down it may be necessary to go as high as 10%. The goal is to have tongue weight that allows for smooth, safe towing.

Weight-Distributing Hitches

Your dealer may recommend a weight-distributing hitch for heavier units. If this type of system is installed, no warranty will apply to the hitch and/or trailer.

Here are several items you should consider before installing this type of system:

It is very important that the weight-distributing hitch is mounted correctly so that there isn't any undue strain applied to both the trailer and tow vehicle.

This type of system dampens the action of the surge hydraulic brake systems causing the brakes either not to be applied as quickly or to be partially applied at all times. This leads to overheated brakes and excessive brake shoe wear. It may also cause bearing failures because the heat build up will disintegrate the grease in the bearings.

TOW VEHICLES

With the popularity of smaller cars and pickups, it has become even more important to know the towing capabilities of your tow vehicle. Before towing your trailer, be sure to read and familiarize yourself with the instructions and warnings supplied with the vehicle. Check your vehicle's owner's guide or with your vehicle's dealer to learn the towing capacities and hitch weight information.

WARNING: Towing a large load with too small of a tow vehicle is very dangerous. Serious injury or property damage can result if the total weight of your loaded trailer exceeds the capacity of the hitch on your tow vehicle.

Several options are available which will help your vehicle's towing ability, including transmission oil coolers, engine oil coolers, proper rear end gear ratios, air shocks, oversize tires, and heavy duty radiators. Your vehicle may come with an optional trailer package that includes most of these items.

It is also important that the lighting system is checked for sufficient capacity due to the added amperage of the lights on the trailer. A heavy duty flasher may be needed to make your turn signals function properly.

Before towing this vehicle always check to ensure:

- *Coupler and latch assembly show no signs of wear or damage
- *Coupler, hitch and hitch ball are the same size
- *Coupler and safety chains are secured to hitch
- *All wheel lug nuts and other fasteners are tight
- *Boat is securely tied down to trailer (winch line is not a tie down)
- *Wheel bearings are properly adjusted and maintained
- *Load is within maximum load carrying capacity
- *Tires are properly inflated
- *All trailer lighting is working properly
- *Trailer brakes, if applicable, are properly adjusted and working

Your trailer is equipped to meet all applicable federal safety standards. Check local and state requirements regarding brakes and any additional equipment that may be required. Installation of some accessories and options may violate state laws governing maximum overall width of trailers. Before installing any option or accessory that could change the overall width and GVWR of the trailer (example: load guides or spare tire), check regulations on maximum trailer width and GVWR in the states you plan to tow your trailer.

The installation of any accessory or option that causes the trailer to be over width or over the GVWR rating stated negates any warranties.

TRAILER BALLS & COUPLERS

WARNING: The hitch ball must be the proper diameter and have a rating equal to or greater than the GVWR of the trailer. Failure to do so may cause possible loss of the trailer and serious injury or property damage.

Trailer couplers are permanently marked with (a) coupler manufacturer name, initials, or trademark, (b) part, style or model number, (c) SAE (Society of Automotive Engineers) coupler designation and gross trailer weight, (d) ball diameter for which rating (GVWR) shall not exceed the gross trailer weight marked on the trailer coupler.

IMPORTANT: Do not use a different size ball than recommended.

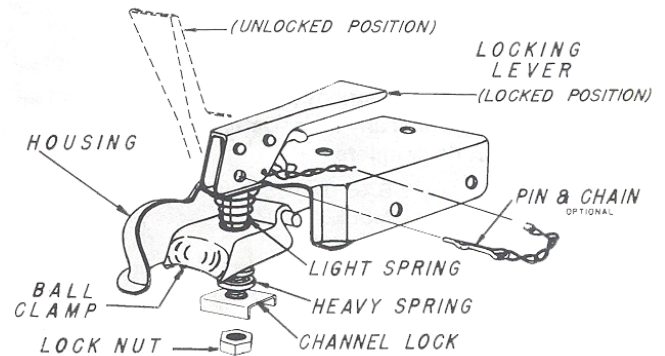

To adjust your Class II and Class III coupler to your trailer ball, remove the coupler from the ball. Reach under the coupler and raise the channel lock up so the nut can be turned. Turn the adjusting nut clockwise to tighten the ball clamp grip on the ball, counterclockwise to loosen ball clamp grip on the ball. Once the nut has been adjusted, make sure the channel lock is positioned back down around the flat surfaces of the nut, so it is locked from turning. Replace the hitch back on the ball and latch. Repeat this process until the ball clamp latches securely around the ball.

The Class IV actuators do not require adjustment.

Class	Coupler	Ball Diameter
II	3,500 lb. GVWR	2"
III	5,000 lb. GVWR	2"
IV	5,000 - 10,000 lb. GVWR	2-5/16"

HITCH COUPLER TROUBLESHOOTING

If the coupler becomes damaged, it must be repaired or replaced before towing. When the coupler is placed on the ball, the latch should close firmly. Keep the latch mechanism lightly oiled and clean.

1. If the latch does not grasp ball securely:
 - A. Check the ball size. Make sure the ball is the correct size for the coupler.
 - B. Unlatch mechanism, reach under ball clamp and raise. Turn adjustment nut clockwise one complete turn. Make sure the nut retainer clip is down in position to keep nut from turning. Relatch on ball. If still loose, repeat process until grasp is tight.
2. If the latch does not snap into full latch position:
 - A. Check adjustment. The latch may be too tight. Loosen reversing procedure in Step #1.
 - B. Check to see that the coupler housing has not been damaged, keeping the ball hitch from fitting completely into housing.
3. Keep tongue on a block of wood so that the coupler mechanism does not lay on the ground.
4. Apply a small amount of grease to ball before hitching coupler.
5. Make sure the latch safety pin is in place before towing.

SAFETY CHAINS

Listed in the chart below are the different class sizes of safety chains and the rated load each chain must be capable of withstanding.

Trailer Class	Trailer Weight GVWR in lbs.	Minimum Braking Strength in lbs.
I to 2,000	2,000
II	2,000 to 3,500	3,500
III	3,500 to 5,000	5,000

Failure to properly attach safety chains between the trailer and tow vehicle can result in a runaway trailer.

WARNING: Before trailering to avoid accidents...

- Hitch only to ball size marked on coupling.
- Ball clamp must capture ball and lever or hand wheel is fully clamped.
- Cross safety chains under coupling.
- Allow only enough slack for turns.

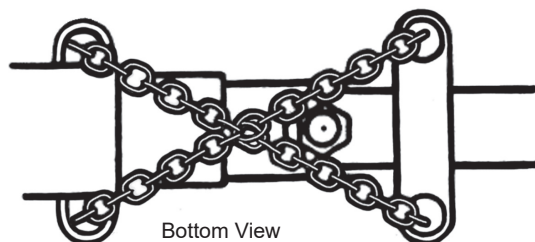

COUPLER & BALL ENGAGEMENT

If the coupler and towing ball resist attempts to make engagement, do not force latch assembly. Instead, check the ball diameter to verify that it conforms to Society of Automotive Engineers (SAE) specifications. Standard two-inch diameter ball should be within the limits of 2.000-inches to 1.970-inches. Balls larger than 2.000-inches will not readily fit the coupler. A two-piece coupler ball is not recommended and will negate all warranties.

If the coupler becomes damaged, it must be repaired or replaced before towing. When the coupler is placed on the ball, the latch should close firmly. Keep the latch mechanism lightly oiled and clean.

Improper engagement of the coupler and ball can cause damage if the vehicles separate in transit; thus, caution must be exercised to insure a secure hook-up. Lower the coupler onto the ball with the coupler latch in the vertical position. Continue to lower the trailer tongue until the jack clears the ground, then flip the coupler latch to its locked (horizontal) position. At this point visually observe that the ball is fully engaged in the ball hitch. An additional check is to raise the tongue of the trailer again using the jack. Raise until the ball hitch connection starts to raise the rear of the tow vehicle. If the connection was not properly made, the ball and socket will separate as the tongue of the trailer is raised.

The safety chains on your trailer are an added insurance that it will not become detached from the tow vehicle. ShoreLand'r provides all safety chains with an added clasp to keep them from becoming accidentally detached from the tow vehicle. Your trailer hitch on the tow vehicle should have two attaching holes or rings for attaching the safety chains, preferably one on each side of the ball hitch. Contact your dealer or Midwest directly if your hitch is not equipped with safety chain attaching points as indicated.

Crisscross the chains under the tongue: the chain on the left side of the trailer tongue attached to the right side of the ball hitch; the chain on the right side of the trailer tongue attached to the left side of the ball hitch.

This prevents the trailer tongue from dropping to the road should the coupler or ball hitch fail. The chains should be rigged as tight as possible with just enough slack to allow tight turns to be made. This can be accomplished by twisting the chain hook in a clockwise or counterclockwise direction, thus twisting the link spacing and making the chain shorter. Also by keeping your chains as short as possible, you prevent them from dragging on the road and wearing the chain links.

If for any reason you find it necessary to replace a safety chain, use only original equipment.

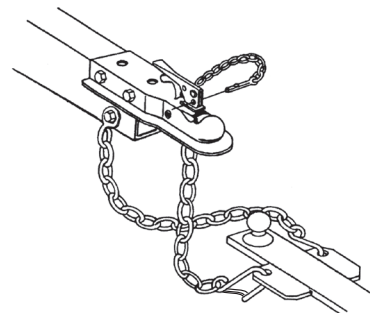

PROPER WINCH POST ADJUSTMENT

Winch post adjustment is a critical part of the trailering process. Improper adjustment can be dangerous and may result in serious damage to the boat, trailer, or both.

The most important part of this adjustment is the proper positioning of the trailer's bow stop roller. Position so it is located just above the boat's bow eye. This is crucial because any downward pull on the front of the boat puts extra weight and pressure on the keel of the boat. The extra pressure can be particularly damaging to boats that feature a live well directly above the trailer's keel support system.

It is equally important that the bow stop roller be located just above the bow eye so that it can stop the boat from being propelled forward in the event of a sudden or panic stop.

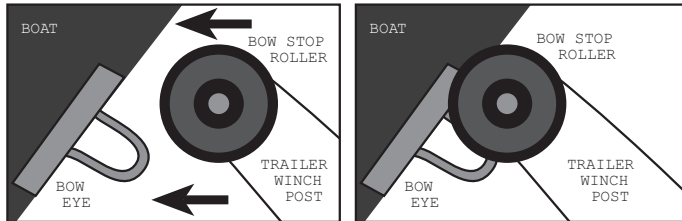

Use the following steps to ensure that the boat is properly secured and minimize the possibility of damage:

1. Position the boat on the trailer and adjust the bunks or rollers to properly support the boat.
2. Adjust the axle for proper tongue weight.
3. Loosen all winch post adjustment bolts and slide the assembly toward the boat, positioning the bow stop roller just above the boat bow eye.
4. Attach the winch strap to the bow eye and wind the winch up tight to hold the winch post and bow eye roller in the new position.
5. Tighten all adjustment bolts loosened earlier to hold the winch post at the new adjustment. Once tightened, loosen the winch strap to double check that the bow eye roller remains just above the boat bow eye.
6. When the adjustment is complete, tighten the winch strap securely. Attach the bow eye safety chain to the bow eye making sure it is attached at all times except when loading and unloading.

BOW EYE SAFETY CHAIN

WARNING: Failure to tie down the bow independently from the winch strap could allow your boat to shift while traveling, causing loss of control of the tow vehicle and result in serious injury and/or property damage.

Bow eye safety chains are provided on all trailers with a carrying capacity greater than 1200 pounds and with models in either a roller or XR frame style. Bow eye safety chains are not supplied on pontoon trailer models, because pontoon trailers are only offered in bunk styles. The bow eye safety chains should be used at all times when transporting the boat in and out of the ramp site as well as towing down the road. It is for your protection and security. USE IT!

WINCH HANDLES

Some ShoreLand'r trailers are equipped with a removable winch handle. Be sure to remove it before towing.

BOW PULPITS & WINCH POST LENGTHS

There are many different configurations on boat bows today including bow pulpits. There are many different shapes and some have anchoring systems attached to them as well. The height of the boat's bow eye will also vary tremendously from one boat manufacturer to another. They all need to be addressed in order to properly secure the boat for towing. This is especially true when it comes to loading and unloading the boat from the trailer.

ShoreLand'r supplies a standard length winch post with each trailer that will adapt to most of the boats that will be placed on that particular trailer. However, this becomes a challenge when dealing with the above mentioned situations. As the boat is being loaded and unloaded on the trailer, the bow will drop down or be in a lower position than what it is when it is fully loaded in the transport position. As a result the bow pulpit clearance to the winch post is less. This is compounded even more when the boat and trailer are backed into deep water so that the back of the boat will float above the trailer during loading and unloading. It is possible at this point that the bow pulpit will strike the top of the winch post as it is being loaded and unloaded. Extra care should be taken when loading and unloading the first several times to make sure that there is ample clearance for your bow pulpit. Your boat may be damaged if it strikes the winch post.

Should you experience the above situation, return it to your authorized ShoreLand'r dealer immediately. It can be corrected a couple different ways.

- ShoreLand'r does offer several different lengths of winch-post in most models.
- Additional modification may be available; have your dealer contact ShoreLand'r for approval. Any modifications made without ShoreLand'r approval may negate all warranties.

TIRE INFORMATION

HOW TO REGISTER YOUR TIRE:

To register your tire, please follow the link that is correct to your tire: This link is the tire registration: <https://www.tredittire.com/guarantees-simplified/>

This link is for the warranty; <https://www.tredittire.com/product-warranty/>

This link is for Carlisle tires: <https://register.cimtireregistration.com/index.cfm?id=carlisle>

OR

Go online to www.carlislebrandtires.com and click on Tire Registration at the bottom of the homepage.

STEPS FOR DETERMINING CORRECT LOAD LIMIT

- Locate the statement: "The weight of cargo should never exceed XXX kg or XXX lbs." on your trailer's placard.
- This figure equals the available amount of cargo and luggage load capacity.
- Determine the combined weight of luggage and cargo being loaded on the vehicle. That weight may not safely exceed the available cargo and luggage load capacity.

TIRE SAFETY

The most common cause of trailer tire failure is under-inflation. It

is important, therefore, that you always maintain the specified air pressure, as indicated by the tire manufacturer on the tire's side walls. This information can also be found on the tire label or the manufacturers certification label. Most tire manufacturers have the air pressure molded on the tire side wall.

Maintaining proper tire pressure, observing all tire and trailer maximum carrying capacities, avoiding road hazards, and inspecting the tires for cuts, slashes and other irregularities are the most important things you can do to avoid tire failure. These practices, along with other care and maintenance, can improve handling, help protect you and others from avoidable breakdowns and accidents, improve fuel economy, and increase the life of your tires.

Make tire safety a regular part of your trailer maintenance routine. The time you spend is minimal compared to the amount of time, inconvenience, and potential safety hazards that can occur from a flat tire or tire failure.

TIRE FUNDAMENTALS

The following information is being provided for the trailer owner's general information. Any questions concerning passenger vehicle tires should be directed to the tire manufacturer.

Federal law requires tire manufacturers to place standardized information on the side wall of all tires. This information identifies and describes the fundamental characteristics of the tire and also provides a tire identification number for safety standard certification and in case of a recall.

INFORMATION ON PASSENGER VEHICLE TIRES

RIMS

WHEEL SIZES

ShoreLand'r uses various size tires on different model trailers to accommodate the load that is being placed on the trailer. This results in the use of different size and width of rims. ShoreLand'r recommends that you use only genuine replacement parts for spare tires. However, should you need to purchase one elsewhere, the following table lists information needed to purchase the right style rim to fit your trailer.

Rim Size	Lug Nuts	Rim Type	Rim Width	Recommended Torque ft./lb.
8"	5	Steel	7"	90
10"	5	Steel	6"	90
12"	5	Steel	4"	90
13"	5	Steel	5"	90
13"	5	Alum	5"	90
14"	5	Steel	6"	90
14"	5	Alum	6"	100
15"	6	Steel	6"	100
15"	6	Alum	6"	100
16"	8	Steel	6"	110
16"	8	Alum	6"	110

RECOMMENDED PROCEDURE FOR MOUNTING WHEELS

WARNING: Maintain proper torque on lug nuts. Failure to do so may result in serious injury or property damage.

All wheels used on ShoreLand'r trailers have a zero offset, meaning that the center mounting face of the wheel is in the center of the tire.

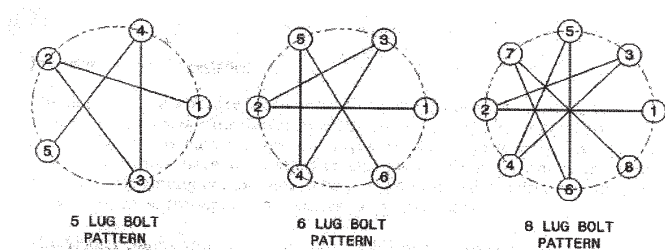

The following procedures apply to both steel and aluminum wheels and must be adhered to very closely when mounting wheels to the hubs.

1. The contact surfaces of both the hubs and wheels must be free of paint, contamination and damage. Smooth, clean surfaces provide the most uniform clamping pressure and best retain torque.
2. Surfaces of contact on the axle (the flat hub surface and the threaded studs) must be free of excessive paint, oils, grease, contamination and physical damage.
3. When replacing a wheel assembly or repairing a flat tire, always remove all dirt, rust, grease and oil from the surfaces as well as the stud threads. Never lubricate the threads.
4. Position the wheel on the hub making sure the two match correctly. This is especially true if a spare wheel assembly or new replacement is being installed. Inspect to make sure there is full contact between the mounting surface (seat pads) of the wheel and the mounting surface of the hub, brake drum or rotor.
5. Start the wheel lug nuts on the studs.
6. Finger tighten the top nut, then rotate the wheel so that the number 2 nut (see diagram) is at the top and then finger tighten.
7. Repeat step 6, rotating the wheel and finger tightening nuts until all nuts are snug.
8. Use a torque wrench or an impact wrench with a torque stick as a tool initially to lightly secure the wheel, applying a criss-cross or star pattern as shown in the diagram.
9. The nuts should be tightened to the appropriate torque listed in the chart. A calibrated torque wrench is recommended for tightening the wheels so that all the nuts are tightened equally. Re-torque nuts again after 50 miles of use and then check for tightness every time before towing.
10. After the wheels with tires have been mounted, visually inspect to insure that the tires are not rubbing any other portion of the trailer or fender. There must be ample clearance for extreme road conditions and sharp turns.
11. In the event that the axles are rusted and you want to paint them, make a mask or shield (cover) to protect all fastener contact surfaces (mounting surfaces and studs) before painting axles, whether for improved cosmetics or for corrosion protection.

The following is a list of "don'ts" when mounting wheels on your trailer.

1. DON'T deviate from the component manufacturer's recom-

mendations regarding compatible components without a competent engineering review.

2. DON'T substitute any component for the components the suppliers have specified without a competent engineering review.
3. DON'T deviate from the component suppliers' fastener torque specifications, where provided, without a competent engineering review.
4. DON'T use adhesive products to maintain fastener tension.
5. DON'T use lubricants or oils on threaded fasteners (studs or lugs) to make applying the torque easier unless assembly specifications require it.
6. DON'T apply any additional paint on fastener contact surfaces (mounting surfaces/hub faces or studs).

ALUMINUM WHEELS PURCHASED FROM ANOTHER SOURCE

Wheel torque may vary from one aluminum wheel manufacturer to another. In the event that you purchased aluminum wheels from a wheel supplier other than ShoreLand'r, it is recommended that you use the torque specifications for that particular wheel.

Aluminum wheels purchased elsewhere must also have a carrying capacity equivalent to the load carrying capacity of an ST rated tire. ST rated tires have a greater carrying capacity than an automotive tire.

Wheels purchased from another supplier are not covered under the stated warranty policy provided with your trailer.

BRAKE INFORMATION

ShoreLand'r provides all trailers with a GVWR (Gross Vehicle Weight Rating) of 1,500 lbs. or more with the ability to have brakes installed on them. On the lower capacity trailers (1,500 - 2,400 lbs.), a special axle adaptable to brakes is part of the brake kit when brakes are ordered for a trailer this size. All trailers with a GVWR of 2720 lbs. or greater come with the brake flanges already welded on the axles so brakes can be added without having to install a different axle.

Most of the trailer brakes are hydraulic surge brakes and are designed to operate automatically when the brakes on the tow vehicle are applied. When the tow vehicle slows down or stops, the forward momentum of the trailer pushing against the ball hitch applies pressure to a master cylinder in the trailer actuator. This pressure activates the brakes on the trailer similar to the brakes on the tow vehicle. This is a hydraulic surge brake system.

ShoreLand'r reserves the right to have its brake vendors provide technical assistance.

Failure to use ShoreLand'r brake vendors negates all warranties relating to and arising from any brake problems.

Contact ShoreLand'r for more technical and specific information on its different brake systems, bleeding and maintenance procedures, as well as who to contact for warranty issues.

BACKING UP A TRAILER WITH DISC BRAKES

Operating Trailers With Disc Brakes

Many ShoreLand'r trailers come with disc brakes as standard equipment. This system is designed to brake in both forward and reverse, therefore the brakes must be disengaged to back up.

IMPORTANT: To properly operate this system the tow vehicle **MUST** be equipped with a matching 5-prong trunk harness to power the solenoid. Otherwise, a lockout key must be used (this key is provided with your actuator).

Trailer's 5-prong Wire Harness Requirements
Required 5-prong trunk harness on tow vehicle.

How the Solenoid Lockout Works

The disc brake actuator has a lockout solenoid that is activated by the tow vehicle's back-up lights. When the vehicle is put in reverse, the solenoid redirects the brake fluid back into the actuator reservoir rather than applying pressure to the brake calipers. Then, when the tow vehicle is put into park, neutral or a forward gear the solenoid returns to its original position allowing the brakes to function normally during travel.

Alternatives to the 5-Prong Harness

As stated above, the best way to operate the solenoid is with a 5-prong wire harness on the tow vehicle that matches the wire harness plug of the trailer. This allows the solenoid to be plugged in at the same time the trailer lights are connected for towing. If a 5-prong harness is not available there are a number of short-term fixes that will allow you to use the trailer.

UFP Actuator Lockout Key

UFP actuators are shipped with a lockout key attached to the side of the actuator on a short cable. The round end of the key is simply inserted in the slot on the side of the actuator. When the key is in the slot, the trailer can be backed without the brakes engaging. When the trailer is moved forward, the key will fall out of the slot. The key fits very loosely to insure that it will not remain in the slot after backing.

WARNING: Leaving the lockout key in the slot would disable the brake system during normal use, which could result in a serious accident.

Adding a 5th Wire & Plug

A separate wire and plug can be wired into the tow vehicle back-up lights to operate the solenoid. Contact your local dealer for assistance with the addition of the fifth wire and plug.

Using a 4-prong Plug

If the tow vehicle is equipped with a 4-prong plug, the trailer can still be moved using the solenoid to lock out the brakes. Though not ideal, this is acceptable for only backing trailers in either a storage yard or a shop environment where the tow vehicle is not the normal vehicle that will be used with the trailer. Before backing, simply unplug the trailer's 5-prong harness from the tow vehicles 4-prong trunk harness. Turn the harness 90 degrees and plug the blue wire on the 5-prong harness into the brown wire on the 4-prong harness. To activate the solenoid, turn on the tow vehicle's lights. The power for operating the running lights will operate the solenoid, disengaging the brakes so the trailer can be backed up.

Modifying the Connection

Turn plug to connect the blue wire to the brown wire.

TIE DOWNS

It is very important that your boat is supported properly by the trailer. It is equally important that your boat stays positioned on the trailer while towing. This is accomplished by securing the boat to the trailer with some type of tie down. There are two types of tie downs to consider:

Bow Tie Down: ShoreLand'r offers one of the best winch post assemblies for adjustment and stability. However, for added security, you should use a separate tie down to tie the bow eye both downward and also forward. This should guard against any sudden stops or starts, or winch or winch strap failure.

Rear Tie Down: It is very important that the transom of your boat is resting fully and securely on the supports provided and that it remains there while transporting. The two most common types of tie downs are the transom tie down strap or else the gunwale tie down. Either system works well and holds your boat solidly on the trailer. Places to fasten the tie downs are provided in either the light brackets or the side frame brackets.

TROUBLESHOOTING & MAINTENANCE

For Parts lookup and directions to a parts dealer:
www.shoreland'r.com/parts, click on - Partsmart Online Parts finder.

LIGHTING

The ShoreLand'r electrical system is virtually trouble-free, especially with the use of the automotive type wire harnesses. This eliminates shorts in the system due to bad or corroded connections. We suggest, however, that you use the following precautions for trouble-free trailering:

1. Disconnect the tongue harness from the tow vehicle before backing the trailer into the water. This will eliminate the bulbs from lighting while submerged in the water. Lighting a submerged light bulb will cause it to burn out.
2. Carry spare bulbs for your trailer. Determine the brand taillight and side marker lights you have by looking at the lens on the light. Their name will appear on it. The replacement bulbs required are as follows:
 - The large replacement bulb is #GE1157 bulb. The small bulb is the #GE194 bulb.
 - Once a year, remove the light lens and spray or coat the metal components with either WD40 or CRC. A light coat of petroleum jelly also works well.
3. Make sure the electrical system on the tow vehicle is capable of powering the additional lights on the trailer. Check with your local automotive dealer for specifications and any options available that will increase the electrical capacity.
4. In order to insure a positive ground connection between the trailer and the tow vehicle, it is important that the white ground wires are secured properly to both the trailer and the towing vehicle. A poor ground connection will cause the lights to not function properly.
5. Many of the new model trailers are equipped with fully-grounded wire harnesses. This means that the grounding for each individual light is connected directly into the wire harness creating a positive ground that is not relying on the ground connection through the frame.
6. Many of the new model trailers are also equipped

with LED lights in all lighting applications. The LED lights are virtually trouble-free and will operate for many miles. However, there is no repairing them when they stop functioning. They will need to be replaced.

PAINT AND ITS CARE

ShoreLand'r offers trailers in various coatings and in a variety of colors on some select models. The painted trailers have a durable powder-coated finish. However, it still requires maintenance and care as does your tow vehicle. Touch-up paint is available in either a bottle with a paint stick or a spray can. All nicks and scratches should be touched up before rusting sets in and starts to deteriorate the finish. An annual waxing of the finish is recommended.

Many lakes are contaminated with materials that have a tendency to attack the trailer finish similar to salt water. Likewise, your trailer may be exposed to salt conditions while towing it down the road. We recommend that you take the time to wash your trailer with soap and water, then rinse thoroughly to remove any residue that may be accumulated on the finish each time you go boating. It should also be washed and rinsed before storing your boat and trailer at the end of the season.

IMPORTANT: Do not allow hull cleaners or other chemicals to settle on the frame. ShoreLand'r will not honor any warranties under these circumstances.

REPACKING BEARINGS

WARNING: Keep wheel bearings lubricated. Failure to properly lubricate may cause bearing failure and possible wheel loss resulting in serious injury or property damage.

As wheels are submerged in water, bearing maintenance is a serious issue. Preventative maintenance is required. This type of maintenance varies greatly because one individual may put his trailer in and out of the water 300 times a year and tow it 1,500 miles, while another individual may back his trailer in the water 6 times a year but tow it 7,000 miles. Some consumers pull their trailer 30 miles, unload the boat in the water for the season, and then load it back up again at the end of the season for the 30 mile trip home.

Because of the many variances in the way people use a trailer, we suggest that bearings be inspected annually for wear and replaced as needed by an authorized ShoreLand'r dealer.

Check the grease in your hubs once a year. In most instances, if a good quality lubricant is used and the lubricant levels are maintained, it may not be necessary to repack the bearings every year. However, should the grease appear to be contaminated or broken down, remove all of the old grease from the bearings and hubs and completely repack. Replace the seals at this same time if removed to prevent any leakage that may occur from damages to the seals when it is removed.

HUBS, BEARINGS, RACES, SEALS & SPINDLE SLEEVES CHART

ShoreLand'r uses the following sizes of hubs on all of its model trailers. Measurements listed are both spindle size and hub size.

Hub Size	Bearing, Race & Seal Size
1-1/16"- 1-1/16" 5 1/2" flange (Tadpul Series) All Others	Inner & Outer Brg. 1-1/16" Inner & Outer Race 1-1/16" Dust Seal (1.250 I.D. – 1.979 O.D.) Dust Seal 1/16" – 1-1/16" spindle sleeve
1-3/8" – 1- 1/16" Disc Brake Rotors Only	Inner Bearing 1-3/8" Inner Race 1-3/8" Outer Bearing 1-1/16" Outer Race 1-1/16" Spring Loaded Dust Seal (1.750 I.D. – 2.565 O.D.) 1-3/8" – 1-1/16" spindle sleeve
1-3/8" – 1- 1/16" Hubs & Brake Drums	Inner Bearing 1-3/8" Inner Race 1-3/8" Outer Bearing 1-1/16" Outer Race 1-1/16" Spring Loaded Dust Seal (1.750 I.D. – 2.565 O.D.) 1-3/8" – 1-1/16" spindle sleeve
1-3/4" – 1-1/4" 12" Brake Drum & Disc Rotor w/ 6 lugs	Inner Bearing 1-3/4" Inner Race 1-3/4" Outer Bearing 1-1/4" Outer Race 1-1/4" Spring Loaded Dust Seal (2.250 I.D. – 3.371 O.D.) Spindle Sleeve
1 -3/4" -1 -3/4" 12" Brake Drum & Disc Rotor w/ 8 Lugs	Inner Bearing 1-3/4" Inner Race 1-3/4" Outer Bearing 1-1/4" Outer Race 1-1/4" Spring Loaded Dust Seal (.250 I.D. – 3.371 O.D.) Spindle Sleeve

USE & SERVICE TIPS FOR WHEEL BEARING PROTECTORS

Bearing protectors create a positive pressure inside the hub. The spring loaded piston in the bearing protector, pushing against the grease on the inside of the hub holds a slight (3 psi), constant pressure inside the hub. Because of this constant internal pressure inside hub, water cannot enter the hub even when it is submerged.

ShoreLand'r offers the bearing protectors as standard equipment on most of our trailer line. We also install stainless steel spindle sleeves which give the seals a non-corroding surface to turn on. ShoreLand'r also use double-lip seals with the bearing protector to help withstand the internal pressures of the grease. We feel these are necessities and would recommend that you do likewise should you decide to install bearing protectors on your trailer as an option. This is very important, especially on brake axles.

For the bearing protector to function properly, hubs must be completely filled with grease. Hubs must contain enough grease to force the spring loaded piston outward approximately 1/8" from its seated position.

Check the hub lubricant level by pressing on the edge of the spring loaded piston inside the bearing protector itself. If you can move or rock the piston, the hub has sufficient grease. Don't add any more! This simple check instantly tells you that the hub is full of grease. If the piston cannot be moved, it's time to add grease. Use a hand operated grease gun only, not a pneumatic or air driven grease gun; they will apply too much grease too quickly into the system. Add only enough to move the piston outward until it rocks approximately 1/8"; 2-3 pumps usually is adequate.

The bearing protector has a built-in automatic pressure relief feature that allows the excess grease to escape in the event it is over-filled. It also helps prevent rear seal damage. When the piston is forced out beyond the "O" ring on which it rides, grease can escape around the edge of the piston and exit through a small hole provided in the bearing protector. If you put too much grease into the hub, it will come right back out this hole as you tow your trailer. This can create an undesirable effect because the excess grease will be tossed outward onto the wheel as it is towed. The bearing protector bra will control this besides keeping road dust from getting into your bearing protector.

When your trailer is new, it is possible that air has been trapped inside the hub during the initial filling. As you tow your trailer, air will work its way out of the hub, but may force a little grease out ahead of it. Add more grease to maintain the piston at about 1/8" outward from the seated position. As soon as all the trapped air works its way out, the grease leakage will stop.

WHEN TO CHECK THE GREASE IN YOUR HUBS

Check the lubricant level when the hub is warm. On boat trailers, we suggest that you check just prior to launching to be sure the hub is full of grease before the axle is submerged.

GREASE SEALS

Inspect the grease seals periodically. A visual inspection is sufficient and is done quite easily on a trailer without brakes. It is normal to see a small oil film around the seal area. However, if grease is thrown out the back of the hub and onto the rim, it is time to replace the seal before too much grease escapes, causing bearing failure. It will also cause the brakes to grab on a brake equipped trailer. Replacement of the seal requires removing the complete hub assembly from the spindle. Trailers equipped with disc brakes will have to have the brake calipers removed so the rotors can be removed from the spindle.

On axles with brake drums a qualified service technician must remove the complete brake drum assembly to inspect the seals. It is important that you check the seals on brake axles periodically to make sure they are not leaking. Leaking seals allows the grease to get on the brake linings thus causing brakes that grab. Eventually the brake linings will become saturated with grease and will have to be replaced.

GREASE SEAL & BEARING PROTECTORS

If you decide to add bearing protectors to an older model trailer or one that is not equipped with bearing protectors, we suggest you install the Spindle Seal Kit available through your dealers. It offers stainless steel sleeves and spring loaded seals for your axle. This will prevent rust from chewing up the seals allowing grease to leak out.

BEARING ADJUSTMENT

The wheel bearings have been adjusted at the factory. To maximize bearing life, however, we suggest that you check the bearing

adjustment periodically to the recommended 18-20”/lbs. of torque and every time the bearings are repacked. Contact an authorized ShoreLand’r dealer for service.

RECOMMENDED LUBRICANT

Over based calcium sulfonate is installed at the factory because it is a very compatible grease that will blend well with most other greases. We recommend that you continue to add over based calcium sulfonate grease to the hubs when grease is needed. ShoreLand’r has this grease available in a 14 oz. tube to fit a stand size grease gun. The part number is 2500038 and can be obtained from any authorized ShoreLand’r dealer. Contact ShoreLand’r directly if a dealer cannot be located. If neither is an option, any good marine grade water resistant grease is recommended.

BRAKE SYSTEM OVERVIEW

Many of the trailers that ShoreLand’r manufactures are equipped with brake systems. ShoreLand’r uses only hydraulic brake systems with basically two types of activating systems. They are as follows:

1. **Hydraulic Surge Brakes:** This system has an actuator on the tongue of the trailer that attaches to the tow vehicle. It is designed that when the brakes are applied on the tow vehicle the trailer will push into the tow vehicle. As this load is applied to the actuator, a master cylinder inside the actuator generates pressure on the brake fluid that is then supplied to the wheel cylinders of the drum brakes or into the calipers on disc brake systems. As this brake fluid is supplied, the pressure is applied to the brake shoes or pads causing the brakes to apply on the trailer.
2. **Electric Over Hydraulic Brakes:** This system has an actuator that is powered by the battery in the tow vehicle. It is controlled by the power supplied to the brake lights of the tow vehicle. When the brakes are applied on the tow vehicle, a signal is sent to the brake lights. This activates the electric over hydraulic system on the trailer, and it then creates pressure on the brake fluid in the system that is supplied to the wheel cylinders or calipers causing the brakes to apply on the trailer.

WARNING: Trailer brakes must be maintained in good working conditions. Loss of adequate braking could result in serious injury or property damage.

The braking systems are covered in much greater detail in the Brake Information Packet that pertains to brake systems and brake components only. Contact your local dealer or contact ShoreLand’r directly to receive a copy of this information.

BASIC TIRE MAINTENANCE

Properly maintained tires ensure the load-carrying capability of your trailer. You can help avoid flat tires and tire failures by maintaining proper tire pressure, observing tire and trailer capacity limits, avoiding road hazards, and inspecting your tires regularly.

TIRES AND TIRE PRESSURES

WARNING: Keep tires properly inflated. Failure to maintain correct tire pressure may result in tire failure and loss of control resulting in serious injury or property damage.

IDENTIFYING YOUR RECOMMENDED TIRE PRESSURE AND MAXIMUM LOAD CARRYING CAPACITY FOR YOUR TRAILER

Both the tire placard and the VIN label are permanently attached to the side frame of your trailer and have the required information printed on them. They also list the maximum load that can be placed on the trailer without exceeding the load limits of the tires or the trailer’s other components. These labels indicate the manufacturers information including:

- Recommended tire size
- Recommended tire inflation pressure
- The maximum weight the trailer is designed to carry
- Gross vehicle weight rating of the trailer
- Gross axle weight rating of the trailer

UNDERSTANDING TIRE PRESSURE & LOAD LIMITS

Tire inflation pressure is the level of air in the tire that provides it with the load-carrying capacity and affects the overall performance of the trailer. The tire inflation pressure is a number that indicates the amount of air pressure that is inside the tire. It is measured in pounds per square inch (PSI). The tire must be inflated to the air pressure as designated on the labels. Also listed on the labels is the air pressure in kilopascals (kPa), which is a metric measurement.

Tire manufacturers determine the air pressure to maximize the amount of weight the tires can safely carry. The proper tire pressure for your trailer tires is referred to as the “recommended cold inflation pressure.” It is difficult to obtain the recommended tire pressure if your tires are not cold when the reading is taken because the air will expand when it is warmed by towing down the road, thus increasing the air pressure inside. If air is added to a tire that is low the air pressure should never exceed the recommended pressure.

It is important to check your trailer’s tire pressure at least once a month for the following reasons:

- Most tires will naturally lose air over time.
- Tires can lose air suddenly if driven over an object that punctures or cuts the tire. Sometimes a sharp blow from a pothole or curb can knock the tire loose from the rim causing immediate deflation.
- Radial tires have an appearance of being under-inflated because of the design and a visual inspection will not always tell you whether the air pressure inside is below its proper operating range.

MAINTAINING PROPER TIRE PRESSURE

1. Locate the recommended tire pressure on the trailer’s tire information placard, certification label or in the owner’s manual.
2. Record the tire pressure of all tires.
3. If the tire pressure is too high in any of the tires, slowly release air by gently pressing on the tire valve stem with the edge of your tire gauge until you get the correct pressure.
4. If the tire pressure is too low, note the difference between the measured tire pressure and the correct tire pressure. These “missing” pounds of pressure are what you will need to add.
5. Add the missing pounds of air pressure to each tire that is under inflated.
6. Check all tires to make sure they have the same air pressure.

If you have been towing your trailer and think that a tire is under

inflated, fill it to the recommended cold inflation pressure indicated on your trailer's tire label placard or the VIN label. You can also check the sidewall of the tire for a correct tire inflation pressure. Your tire will have a slightly lower air pressure because the tire is warm when you are inflating it, but it will be much better than to continue to tow it with the under inflation. Once the trailer has been parked long enough to allow the tires to cool down, recheck the tire pressure and add additional air to return the tire pressure to the recommended level.

TIRE SIZE

To maintain the trailer's carrying capacity and safety, purchase only the same size tires as what were originally supplied on the trailer. The tires on the trailer are an ST rated tire. This means that they are a Special Trailer service tire that has more load carrying capacity than a comparable size tire automotive grade tire. The carrying capacity molded on the side wall of an automotive tire must be reduced by 10% if it is going to be used on a trailer.

Look at the tire information placard, the owner's manual, or the side wall of the tire you are replacing to find this information. If you have any questions about the correct size to choose, consult your ShoreLandr's dealer or local tire dealer for assistance.

TIRE TREAD

The tire tread provides a gripping action to the road to prevent it from sliding on the road surface when cornering and also to help in braking in the event that your trailer is equipped with brakes. Tires are not as safe when the tire tread is worn down to less than 1/16 inch tread. This is easily identified because most tires are manufactured with tread wear indicators that let you know when the tires are worn to the point they should be replaced. These indicators are raised sections spaced intermittently in the bottom of the grooves. When the tread has worn down to the point that they appear to be even with the outside of the tread, it is time to replace the tire. Another method for checking tread depth is to place a penny in the tread with Lincoln's head upside down and facing you. If you can see the top of Lincoln's head, you are ready for new tires.

TIRE BALANCE AND WHEEL ALIGNMENT

To avoid vibration or shaking of the trailer when it is towed, the tires must be properly balanced. Unbalanced tires, when rotated, will cause vibration. The more they are out of balance, the more the vibration will be. This vibration can be eliminated by positioning weights on the wheel to counterbalance heavy spots on the wheel and tire assembly. Most any tire store or service station that deals with tires has the capability of balancing tires.

The wheel must be positioned so that they rotate in the same line as the trailer rather than at some slight angle either inward or outward from this line. If they are not aligned correctly, they will have a tendency to skid down the road causing the tread to wear off quickly and unevenly. Correct alignment maximizes the life of your tires. This is preset when the axles are welded during manufacturing. This alignment is correct and will remain correct when towed under most towing conditions. Hitting curbs and large pot holes with the trailer tires may distort the axle and cause the spindle position to be knocked out of alignment.

TIRE REPAIR

The proper repair of a punctured tire requires a plug for the hole

and a patch for the area inside the tire that surrounds the punctured hole. Punctures through the tread can be repaired if they are not too large, but punctures to the side wall should not be repaired. Tires must be removed from the rim to be properly inspected before being plugged and patched.

CHANGING TIRE

It is desirable that you carry a jack that will work on your trailer in the event that you have a flat tire. A small board or block can also be very beneficial in the event you are jacking on soft dirt or hot asphalt. The jack, depending on the style, may be placed under the side frame in back of the wheel or also under the axle. When placing the jack under the axle, the following precautions should be taken:

- The jack must be placed under the axle as close to the spring as possible.
- If your trailer is equipped with a channel axle, a 2 x 4 x 8" wood block must be placed between the jack and the axle positioned so that the wood block contacts the entire underside of the axle channel.
- Any other jacking procedures may cause damage to the axle and void warranty.

EXCESSIVE TIRE WEAR

Each axle that ShoreLand'r manufactures has been preset when welded for proper caster and camber. If you are experiencing excessive tire wear, it is possible that your axle has been knocked out of alignment by hitting a curb or large pothole. The caster and camber can be checked out and may be corrected by a mechanic with wheel aligning equipment.

USING YOUR SHORELAND'R

Located on the winch post of your trailer, you will find a decal listing safety instructions (safety decal is shown on the right side of this page). Read and understand the information provided before you attempt to tow the trailer.

In addition to the above mentioned safety checks, it is equally important that you check the boat support system of your trailer to make sure that nothing has broken, come loose during the last towing, or fallen off and lost in the roadway. It is very important to the support of your boat that it is properly adjusted and remains properly adjusted.

This trailer is equipped to meet applicable U.S. Federal safety standards. Check local and state requirements regarding brakes and any additional equipment that may be required. Any modifications or additions including load equalizing hitches, without written factory consent, usage in an abnormal manner, including overloading, voids all manufacturer's warranties and liability.

SAFETY INSTRUCTIONS

Proper tongue weight must be maintained.

Before towing, check the following to ensure that:

1. All parts, bolts, nuts and wheel lug nuts are tight.
2. All wheel lug nuts must be tightened to a minimum torque rating of 85 ft/lb.
3. Lug nuts must be re-torqued after the first 50 miles, then periodically thereafter.
4. Tires are inflated to manufacturer's standards. (See tire sidewall)
5. Wheel bearings have adequate grease.
6. Hitch ball is the proper diameter and has a rating equal to or greater than the GVWR of the trailer.
7. Coupler is properly attached and secured to coupler ball.
8. Trailer safety chains are crossed under the tongue and attached to towing vehicle.
9. All lights are operational. Note: It is recommended that the trailer lights be disconnected before backing into the water.
10. Tie downs, winch strap and bow-eye safety chain are secure.
11. Trailer tongue jack is in up or travel position.

Refer to your **ShoreLand'r** Owner's Guide and other decals on trailer for additional information.

Rev C 8/28/06

4810709

WARNING & PRECAUTIONS:

- Respect your winch. High forces are created when using a winch, creating potential safety hazards. It should be operated and maintained in accordance with manufacturer's instructions. Never allow children or anyone who is not familiar with the operation of the winch to use it.
- Check for proper ratchet operation on each use of the winch. Do not use if damaged. Seek immediate repairs.
- Maintain a firm grip on the winch handle at all times. Never release handle when ratchet lever is in unlocked position with a load on the winch or handle will spin violently, which could cause personal injury.
- Never use the winch handle as a handle for pulling or maneuvering the entire trailer. Never pull on the winch handle against a locked ratchet.
- Never apply load on winch with line fully extended. Keep at least three full turns of line on the reel.
- Secure the load properly. When winching operation is complete, do not depend on winch to support the load.
- Using a winch line or line hook which is damaged or worn can result in serious personal injury or damage to the boat.
- Stand to one side when winching the boat onto your trailer to reduce the risk of serious injury should the winch line or hook break.
- Never step inside or on the trailer frame during the launching or loading procedures.
- Never stand behind the towing vehicle when the boat is being driven on the trailer.
- Never stand on the frame during the loading and unloading process, especially when the frame is wet.
- Never dismount from the loaded boat or machine by jumping. Doing so could cause serious injury.

Some larger boats have bow pulpits that extend forward from the boat. In some instances, the bow pulpits present a hazard as the boat is being loaded and unloaded. The following decal identifies these hazards and are things that you must familiarize yourself with if your boat has a bow pulpit.

⚠ CAUTION

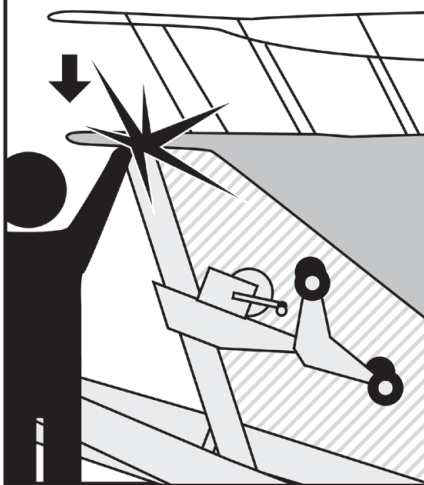

PINCH POINT

Use caution and keep others clear of winch post during launching and loading operations!

Serious personal injury and/or damage to the craft could result.

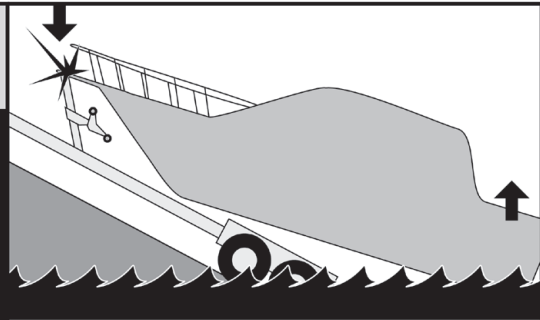

Boats with bow pulpits pose a potential hazard if the pulpit comes in contact with the top or any portion of the winch post or bow stop during launching and loading operations.

If this happens, consult your Owner's Manual, contact your Dealer, or call Midwest Industries Customer Service at (712) 364-3365.

4811425

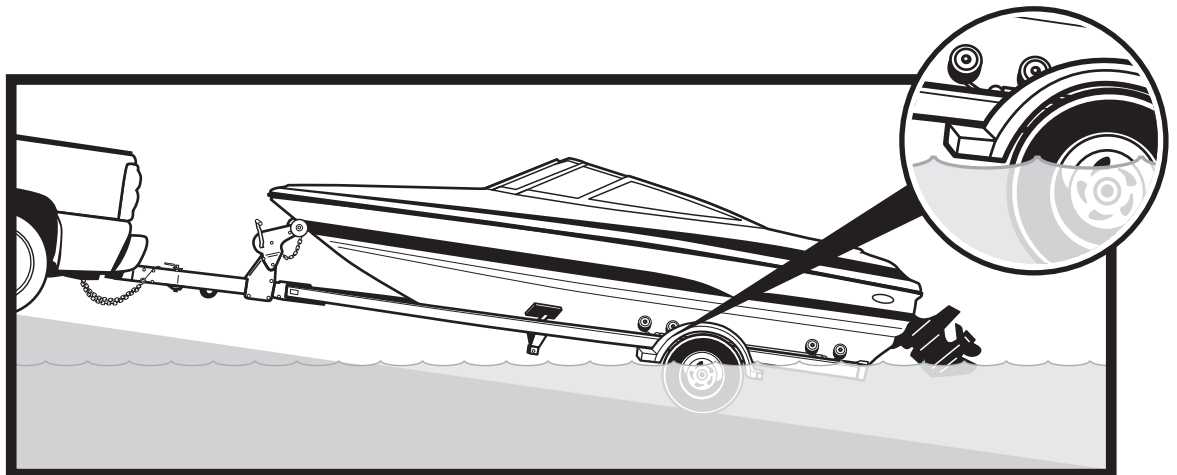
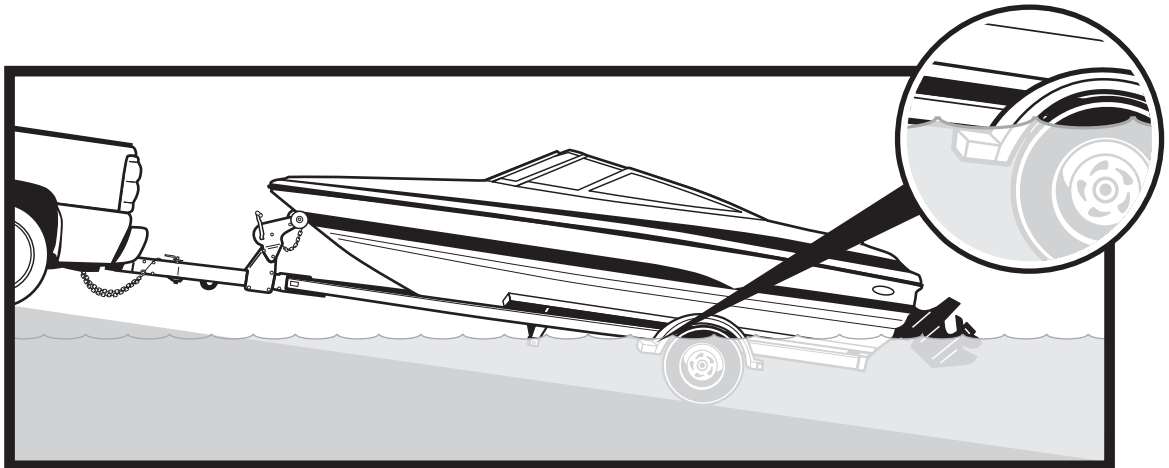

TRAILERING TIPS

Preparing, Backing, Launching & Loading

The ramp is probably the most congested and confused area that you will experience during your boating excursion. Therefore, we provide a few pointers which you as a boater should be aware of that will make life at the ramp more pleasurable for everyone. While you are waiting for your turn at the ramp, you should prepare your boat for launching.

Attach a bow line to your boat and detach trailer tie downs. Do not unhook the bow eye safety chain if your trailer is equipped with one. If your boat is an outboard or stern drive, tilt up the lower unit. Make sure the drain plug is installed in your boat to avoid flooding and/or swamping your boat.

Backing the Trailer at the Ramp

Have someone stand to one side of the ramp to direct you. Backing up a trailer can be tricky. A good way to simplify the procedure is to grasp the steering wheel with one hand at its lowest point (at 6 o'clock). When you want the trailer to go right, move your hand on the wheel to the right; to make the trailer go left, move your hand to the left. The farther you move your hand, the sharper the turn becomes.

Launching

Back your trailer into the water until the front step (if equipped with a step) is at water level. This is a water level guide that you can use at most ramps and is a place to start unless you are at an extremely flat ramp. You will have to back into the water farther on extremely flat ramps while steeper ramps do not require backing in as deeply. This is something that you will have to experiment with to determine what depth to back your trailer in the water for best loading and launching operations.

Set the parking brake and gear shift. Unlock the winch, unhook strap, and then unhook the safety chain, push the boat slowly but firmly off the trailer into the water. Be sure your partner has a firm hold on the bow line.

CAUTION: Make sure your bow line is long enough and that you have a good hold on the rope before launching.

Loading:

The ramp will be equally congested and confusing when trying to load. Again, back the trailer into the water following the same instructions as stated for launching.

- Prepare your boat for being winched on the trailer. Bring your boat over to the trailer with the mooring rope. With the winch in the neutral position, grab the winch strap and unwind the winch strap. Hook the winch hook into the bow eye of the boat. Place the winch latch into the lock position for cranking the boat on the trailer. Winch slowly at first, giving the boat time to swing around into position and center itself for being pulled onto the trailer. This is necessary especially with a cross-current or cross-wind. Crank the boat completely onto the trailer. Hook the bow eye safety chain and tilt the motor so it doesn't hit the ramp when removing the boat. Pull the unit out of the ramp area.

CAUTION: Never jump from the boat or machine. Doing so may cause personal injury from jumping onto rocks, cans, glass or sharp objects that may be hidden under water.

Drive-on Loading (Where Regulations Permit):

- Some boaters prefer to drive their boats on the trailers. Keep in mind that you should not back into the water too deeply. If you are in too deep of water, the trailer loses all of its centering capabilities because your boat is floating on the water above the trailer. Loading your unit several times will give you a better feel for the water depth necessary to back your trailer in.
- Drive your boat on carefully and try to contact the center of the trailer as much as possible. If you do not contact the center of the trailer, just keep slight pressure on the boat at slow throttle and at this point drive the boat like you would a car. If you are to the left of center on the trailer, turn your boat so the front will go to the right, reverse the procedure if you are to the right; of center. At this point, line the front of the boat so it is headed right into the bow stop on the winch stand, adjusting it by turning the rear of your boat like a car.

CAUTION: Do not over throttle when driving the boat onto the trailer. Too much throttle can make the boat uncontrollable and cause damage to boat and trailer.

- If the trailer is adjusted properly, the boat should not only be setting on the trailer straight but also land perfectly into the bow stop. Occasionally if the approach to the trailer is at a very severe angle and the boat ends up setting crooked it may be necessary to back the boat off of the trailer, letting it center itself on the way off, then drive it back onto the trailer.
- Once the boat is up to the bow stop, leave the throttle slightly open so as to apply enough force to keep the boat on the trailer until the bow eye safety chain and the winch rope can be hooked and secured. At that point, the engine may be stopped and be prepared for removal from the water. Pull unit out of ramp area.
- Once the unit is out of the loading area, then prepare for your trip home. Replace the tie downs, pull the drain plugs, get the drive unit in proper position for transporting, repack gear, re-plug wire harness into the tow vehicle. Be sure and check all points mentioned on the winch post decals again before towing.

IMPORTANT: Bow eye safety chains are provided on all trailers with a carrying capacity greater than 1200 pounds and with models in either a roller or XR frame style. Bow eye safety chains are not supplied on pontoon trailer models, because pontoon trailers are only offered in bunk styles. The bow eye safety chains should be used at all times when transporting the boat in and out of the ramp site as well as towing down the road. It is for your protection and security. **USE IT!**

Please refer to the diagram below.

The “ST” indicates the tire is a special trailer tire.
The “LT” indicates the tire is a light truck tire.

NEXT NUMBER

This three-digit number gives the width in millimeters of the tire from side wall edge to side wall edge. In general, the larger the number, the wider the tire.

NEXT NUMBER

This two-digit number, known as the aspect ratio, gives the tire's ratio of height to width. Numbers of 70 or lower indicate a short side wall for improved steering response and better overall handling on dry pavement.

R

The “R” stands for radial. Radial ply construction of tires has been the industry standard for the past 20 years. A “D” stands for bias ply construction.

NEXT NUMBER

This two-digit number is the wheel or rim diameter in inches. If you change your wheel size, you will have to purchase new tires to match the new wheel diameter.

U.S. DOT TIRE IDENTIFICATION NUMBER

This begins with the letters “DOT” and indicates that the tire meets all federal standards. The next two numbers or letters are the plant code where it was manufactured, and the last four numbers represent the week and year the tire was built. For example, the numbers 3197 means the 31st. week of 1997. The other numbers are marketing codes used at the manufacturer's discretion. This information is used to contact consumers if a tire defect requires a recall.

TIRE PLY COMPOSITION AND MATERIALS USED

The number of plies indicates the number of layers of rubber-coated fabric in the tire. In general, the greater the number of plies, the more weight a tire can support. Tire manufacturers also must indicate the materials in the tire, which include steel, nylon, polyester, and others.

MAXIMUM LOAD RATING

This number indicates the maximum load in kilograms and pounds that can be carried by the tire.

MAXIMUM PERMISSIBLE INFLATION PRESSURE

This number is the greatest amount of air pressure that should ever be put in the tire under normal driving conditions.

UTQGS (Uniform Tire Quality Grading System) INFORMATION

TREAD WEAR NUMBER

This number indicates the tire's wear rate. The higher the tread wear number is, the longer it should take for the tread to wear down. For example, a tire graded 400 should last twice as long as a tire graded 200.

TRACTION LETTER

This letter indicates a tire's ability to stop on wet pavement. A higher graded tire should allow you to stop your car on wet roads in a shorter distance than a tire with a lower grade. Traction is graded from highest to lowest as “AA”, “A”, “B”, and “C”.

TEMPERATURE LETTER

This letter indicates a tire's resistance to heat. The temperature

grade is for a tire that is inflated properly and not overloaded. Excessive speed, under-inflation or excessive loading, either separately or in combination, can cause heat build-up and possible tire failure. From highest to lowest, a tire's resistance to heat is graded as “A”, “B”, or “C”.

ADDITIONAL INFORMATION ON LIGHT TRUCK TIRES

Please refer to diagram below.

Tires for light trucks have other markings besides those found on the side walls of passenger tires.

LT

The “LT” indicates the tire is for light trucks.

MAX. LOAD DUAL kg (lbs.) AT kPa (psi) COLD

This information indicates the maximum load and tire pressure when the tire is used as a dual, that is, when four tires are put on each rear axle (a total of six or more tires on the vehicle).

MAX. LOAD SINGLE kg (psi) AT kPa (psi) COLD

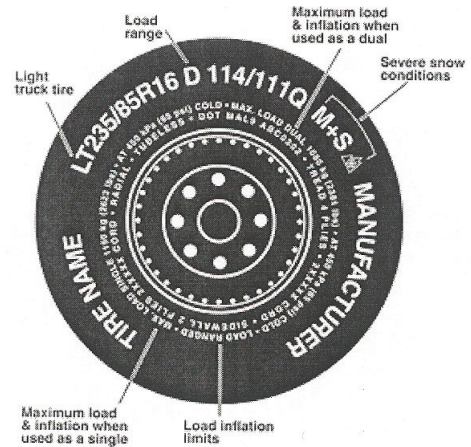

This information indicates the maximum load and tire pressure when the tire is used as a single.

LOAD RANGE

This information identifies the tire's load-carrying capabilities and its inflation limits.

SNOW TIRES

In some heavy snow areas, local governments may require true snow tires, those with very deeply cut tread. These tires should only be used in pairs or placed on all four wheels. Make sure you purchase snow tires that are the same size and construction type as the other tires on your vehicle.

GLOSSARY OF TIRE TERMINOLOGY

ACCESSORY WEIGHT

The combined weight (in excess of those standard items which may be replaced) of automatic transmission, power steering, power brakes, power windows, power seats, radio and heater, to the extent that these items are available as factory-installed equipment (whether installed or not).

BEAD

The part of the tire that is made of steel wires, wrapped or reinforced by ply cords and that is shaped to fit the rim.

BEAD SEPARATION

This is the breakdown of the bond between components in the

bead.

BIAS PLY TIRE

A pneumatic tire in which the ply cords that extend to the beads are laid at alternate angles substantially less than 90 degrees to the center line of the tread.

CARCASS

The tire structure, except tread and side wall rubber which, when inflated, bears the load.

CHUNKING

The breaking away of pieces of the tread or side wall.

COLD INFLATION PRESSURE

The pressure in the tire before you tow.

CORD

The strands forming the plies in the tire.

CORD SEPARATION

The parting of cords from adjacent rubber compounds.

CRACKING

Any parting within the tread, side wall, or inner liner of the tire extending to cord material.

CT

A pneumatic tire with an inverted flange tire and rim system in which the rim is designed with rim flanges pointed radially inward and the tire is designed to fit on the underside of the rim in a manner that encloses the rim flanges inside the air cavity of the tire.

CURB WEIGHT

The weight of a motor vehicle with standard equipment including the maximum capacity of fuel, oil, and coolant, and if so equipped, air conditioning and additional weight optional engine.

EXTRA LOAD

A tire designed to operate at higher loads and at higher inflation pressures than the corresponding standard tire.

GROOVE

The space between two adjacent tread ribs.

INNER LINER

The layer(s) forming the inside surface of a tubeless tire that contains the inflating medium within the tire.

INNER LINER SEPARATION

The parting of the inner liner from cord material in the carcass.

INTENDED OUTBOARD SIDEWALL

The side wall that contains a white-wall, bears white lettering or bears manufacturer, brand, and/or model name molding that is higher or deeper than the same molding on the other side wall of the tire or the outward facing side wall of an asymmetrical tire that has a particular side that must always face outward when mounted on a vehicle.

LIGHT TRUCK (LT) TIRE

A tire designed by its manufacturer as primarily intended for use on lightweight trucks or multipurpose passenger vehicles.

LOAD RATING

The maximum load that a tire is rated to carry for a given inflation pressure.

MAXIMUM LOAD RATING

The load rating for a tire at the maximum permissible inflation pressure for that tire.

MAXIMUM PERMISSIBLE INFLATION PRESSURE

The maximum cold inflation pressure to which a tire may be inflated.

MAXIMUM LOADED VEHICLE WEIGHT

The sum of curb weight, accessory weight, vehicle weight, and production options weight.

MEASURING RIM

The rim on which a tire is fitted for physical dimension requirements.

NON-PNEUMATIC RIM

A mechanical device which, when a non-pneumatic tire assembly incorporates a wheel, supports the tire, and attaches, either integrally or separably, to the wheel center member and upon which the tire is attached.

NON-PNEUMATIC SPARE TIRE ASSEMBLY

A non-pneumatic tire assembly intended for temporary use in place of one of the pneumatic tires and rims that are fitted to a passenger car in compliance with the requirements of this standard.

NON-PNEUMATIC TIRE

A mechanical device which transmits, either directly or through a wheel or wheel center member, the vertical load and tractive forces from the roadway to the vehicle, generates the tractive forces that provide the directional control of the vehicle and does not rely on the containment of any gas or fluid for providing those functions.

NON-PNEUMATIC TIRE ASSEMBLY

A non-pneumatic tire, alone or in combination with a wheel or wheel center member, which can be mounted on a vehicle.

NORMAL OCCUPANT WEIGHT

This means 68 kilograms (150 lbs.) times the number of occupants.

OCCUPANT DISTRIBUTION

The distribution of occupants in a vehicle as specified.

OPEN SPLICE

Any parting at any junction of tread, side wall, or inner liner that extends to cord material.

OUTER DIAMETER

Then overall diameter of an inflated new tire.

OVERALL WIDTH

The linear distance between the exteriors of the side walls of an inflated tire, including elevations due to labeling, decorations, or protective band or ribs.

PLY

A layer of rubber-coated parallel cords.

PLY SEPARATION

A parting of rubber compound between adjacent plies.

PNEUMATIC TIRE

A mechanical device made of rubber, chemicals, fabric and steel or other materials, that, when mounted on an automotive wheel, provides the traction and contains the gas or fluid that sustains the

load.

PRODUCTION OPTIONS WEIGHT

The combined weight of those installed regular production options weighing over 2.3 kilograms (5 lbs.) in excess of those standard items which they replace, not previously considered in curb weight or accessory weight, including heavy duty brakes, ride levelers, roof rack, heavy duty battery, and special trim.

RADIAL PLY TIRE

A pneumatic tire in which the ply cords that extend to the beads are laid at substantially 90 degrees to the center line of the tread.

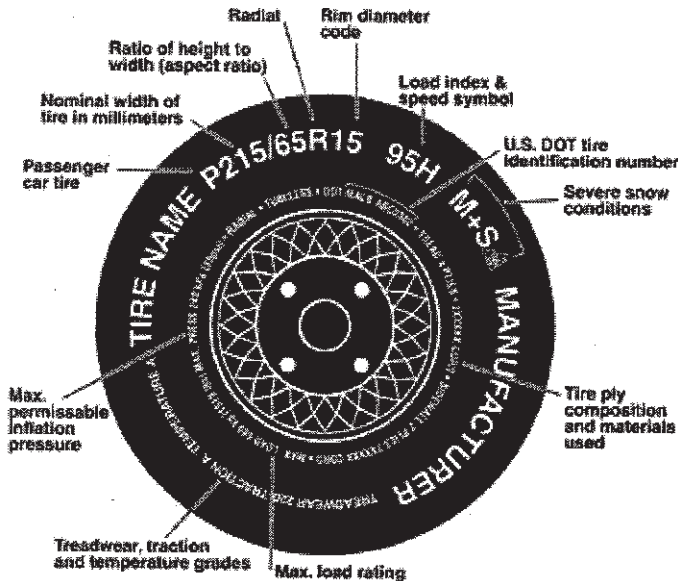

RECOMMENDED INFLATION PRESSURE

This is the inflation pressure provided by the vehicle manufacturer on the Tire Information Label and the Certification/ VIN tag.

REINFORCED TIRE

A tire designed to operate at higher loads and at higher inflation pressures than the corresponding standard tire.

RIM

A metal support for a tire or a tire and tube assembly upon which the tire beads are seated.

RIM DIAMETER

This means the nominal diameter of the bead seat.

RIM SIZE DESIGNATION

This means the rim diameter and width.

RIM TYPE DESIGNATION

This means the industry of manufacturer's designation for a rim by style or code.

RIM WIDTH

This means the nominal distance between rim flanges.

SECTION WIDTH

The linear distance between the exteriors of the side walls of an inflated tire, excluding elevations due to labeling, decoration, or protective bands.

SIDEWALL

That portion of a tire between the tread and bead.

SIDEWALL SEPARATION

The parting of the rubber compound from the cord material in the side wall.

TEST RIM

The rim on which a tire is fitted for testing, and may be any rim listed as appropriate for use with that tire.

TREAD

That portion of a tire that comes into contact with the road.

TREAD RIB

A tread section running circumferential around a tire.

TREAD SEPARATION

Pulling away of the tread from the tire carcass.

TREAD INDICATORS (TWI)

The projections within the principal grooves designed to give a visual indication of the degrees of wear of the tread.

VEHICLE CAPACITY WEIGHT

The rated cargo and luggage load plus 68 kilograms (150 lbs.) times the vehicles designated seating capacity.

VEHICLE MAXIMUM LOAD ON THE TIRE

The load on an individual tire that is determined by distributing to each axle its share of the maximum loaded vehicle weight and dividing by two.

VEHICLE NORMAL LOAD ON THE TIRE

The load on an individual tire that is determined by distributing to each axle its share of the curb weight, accessory weight, and normal occupant weight divided by two.

WEATHER SIDE

The surface area of the rim not covered by the inflated tire.

WHEEL CENTER MEMBER

In the case of a non-pneumatic tire assembly incorporating a wheel, a mechanical device which attaches, either integrally or separable, to the non-pneumatic rim and provides the connection between the non-pneumatic rim and the vehicle; in the case of a non-pneumatic tire assembly not incorporating a wheel, a mechanical device which attaches, either integrally or separately, to the non-pneumatic tire and provides the connection between tire and the vehicle.

WHEEL-HOLDING FIXTURE

The fixture used to hold the wheel and tire assembly securely during testing.

REPORTING SAFETY DEFECTS

If you believe that your vehicle has a defect which could cause a crash or could cause injury or death, you should immediately inform the National Highway Traffic Safety Administration (NHTSA) in addition to notifying us.

If NHTSA receives similar complaints, it may open an investigation, and if it finds that a safety defect exists in a group of vehicles, it may order a recall and remedy campaign. However, NHTSA cannot become involved in individual problems between you, your dealer, or us.

To contact NHTSA, you may either call the Auto Safety Hotline toll-free at 1-888-327-4236 (TTY: 1-800-424-9153); or go <http://www.safercar.gov>; or write to: NHTSA, U.S. DOT 1200 New Jersey Ave. S.E. Washington D.C. 20590.

You can also obtain other information about motor vehicle safety from <http://www.safercar.gov>.

To contact us: call toll-free 1-800-859-3028, or write to: Midwest Industries, Inc., Customer Service Department, 122 East State Hwy.175, Ida Grove, Iowa 51445.

WARRANTY

Warranty information is within your Owner's Packet. Contact your dealer for service or information on warranty. If warranty, or other information was not included with your trailer, you may request this information at www.shorelandr.com or call Midwest Industries (home of ShoreLand'r) directly at 800.859.3028.

PARTS LOOK-UP & SALES

For genuine ShoreLand'r parts, please see your ShoreLand'r dealer. For accurate parts sourcing, please have your trailer's vehicle identification number (VIN). For more information, please go to www.shorelandr.com and click on 'Parts'.

